



PA-28-161 WARRIOR II



OPERATING DATA MANUAL

Just Flight

PA-28-161 WARRIOR II

Operating Data Manual

CONTENTS

STALL PERFORMANCE	3
Stall speed.....	3
TAKE-OFF PERFORMANCE	4
Normal short field ground roll distance (no obstacle).....	4
Normal short field take-off distance (no obstacle).....	5
Obstacle clearance short field ground roll distance.....	6
Obstacle clearance short field take-off distance	7
CLIMB PERFORMANCE	8
Climb performance.....	8
Fuel, time and distance to climb.....	9
LEVEL FLIGHT PERFORMANCE	10
Best power cruise performance	10
Best economy cruise performance	11
Best power mixture range	12
Best economy mixture range	13
Endurance.....	14
DESCENT PERFORMANCE	15
Fuel, time and distance to descend.....	15
Glide performance.....	16
LANDING PERFORMANCE	17
Landing performance	17

STALL PERFORMANCE

Stall speed

Example

Gross weight: 2,170 lb

Angle of bank: 20°

Flap position: 40°

Stall speed: 44 KIAS

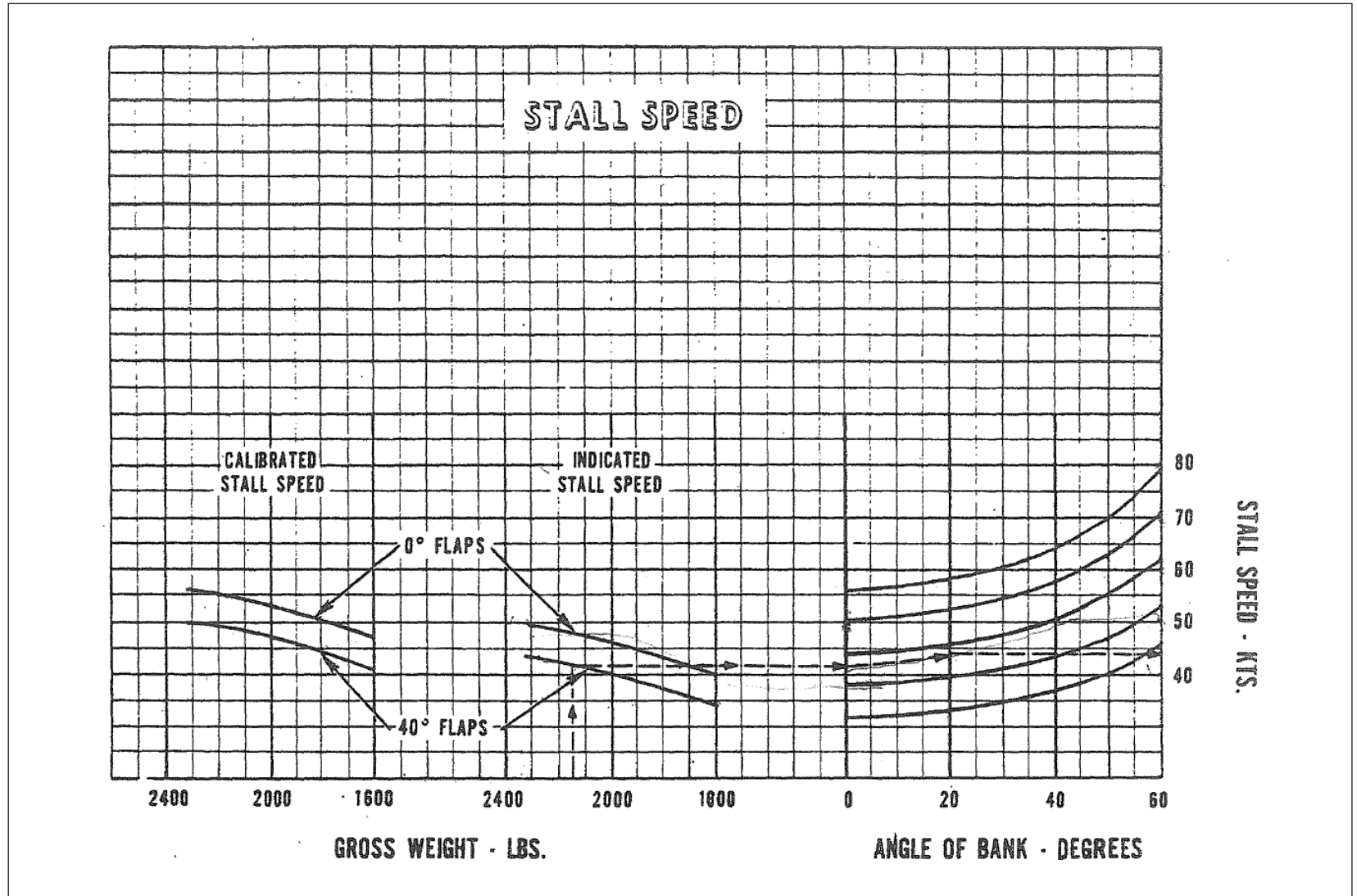

TAKE-OFF PERFORMANCE

Normal short field ground roll distance (no obstacle)

Example

Departure airport pressure altitude: 1,500ft

Departure airport temperature: 80°F (27°C)

Weight: 2,325 lb

Wind: 15 knots headwind

Lift-off speed: 50 KIAS

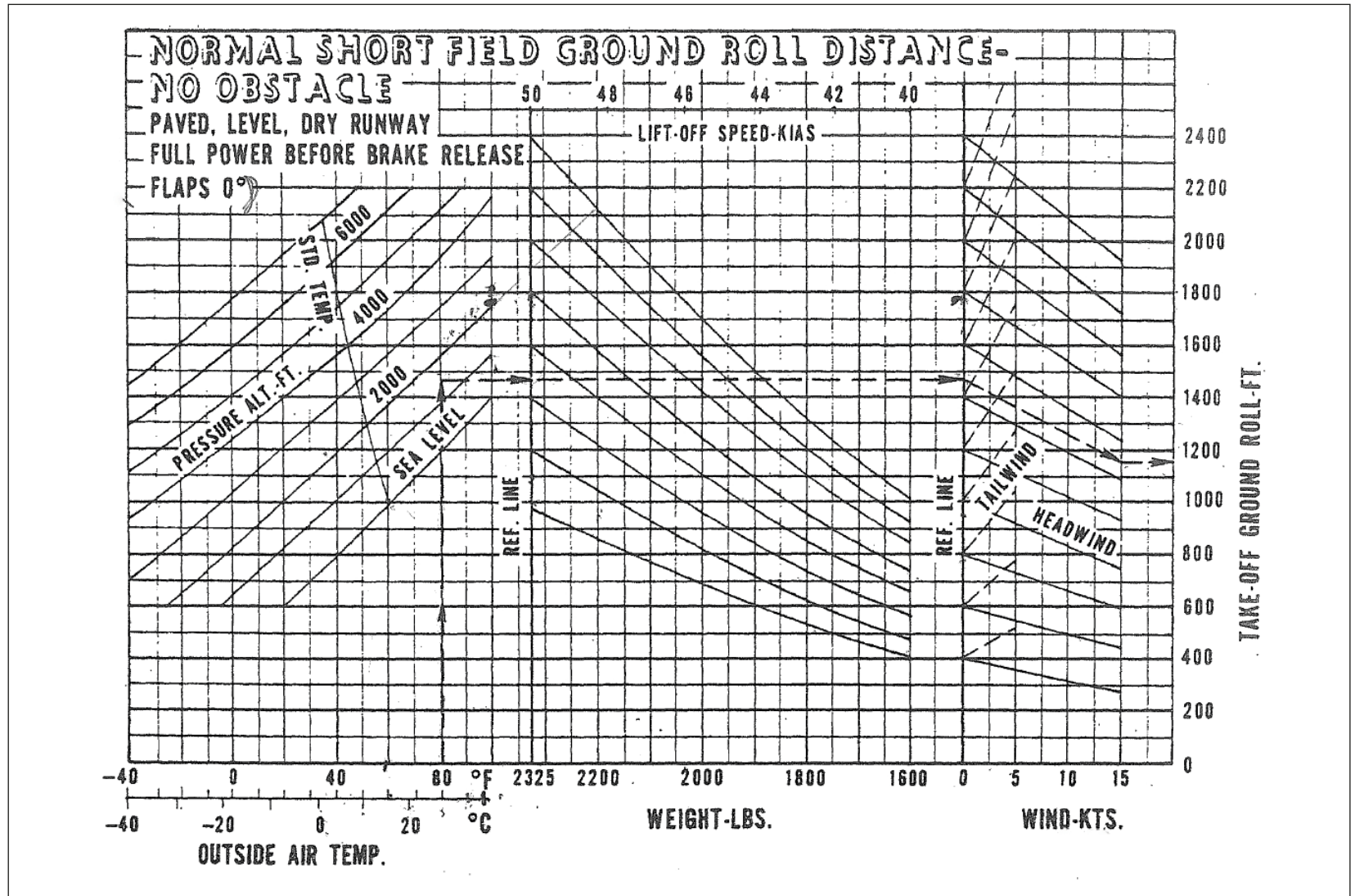

Normal short field take-off distance (no obstacle)

Example

Departure airport pressure altitude: 1,500ft

Departure airport temperature: 80°F (27°C)

Weight: 2,325 lb

Wind: 15 knots headwind

Distance over 50ft barrier: 2,100ft

Lift-off speed: 50 KIAS

Barrier speed: 55 KIAS

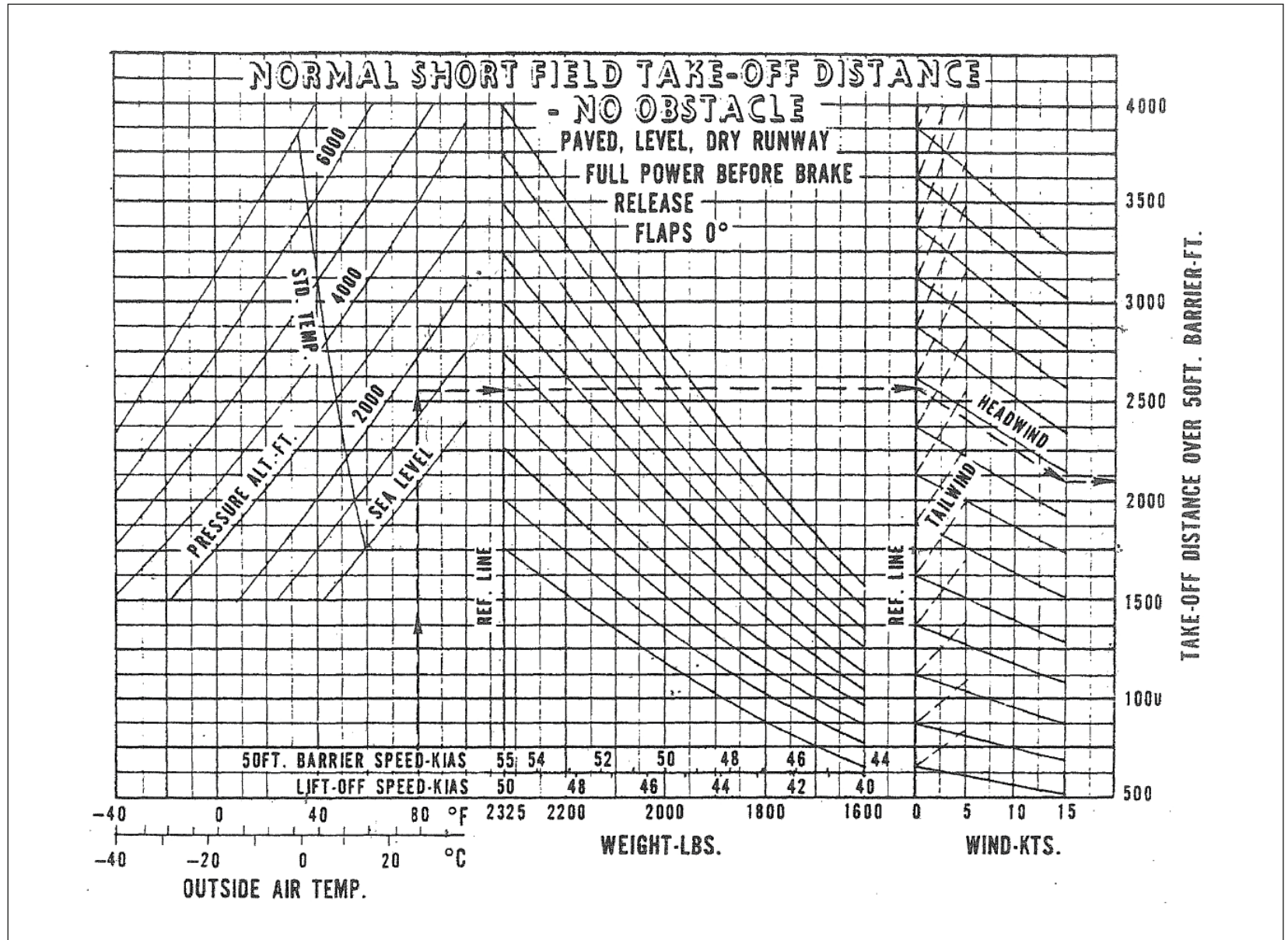

Obstacle clearance short field ground roll distance

Example

Departure airport pressure altitude: 1,500ft

Departure airport temperature: 80°F (27°C)

Weight: 2,175 lb

Wind: 15 knots headwind

Ground roll: 975ft

Lift-off speed: 48 KIAS

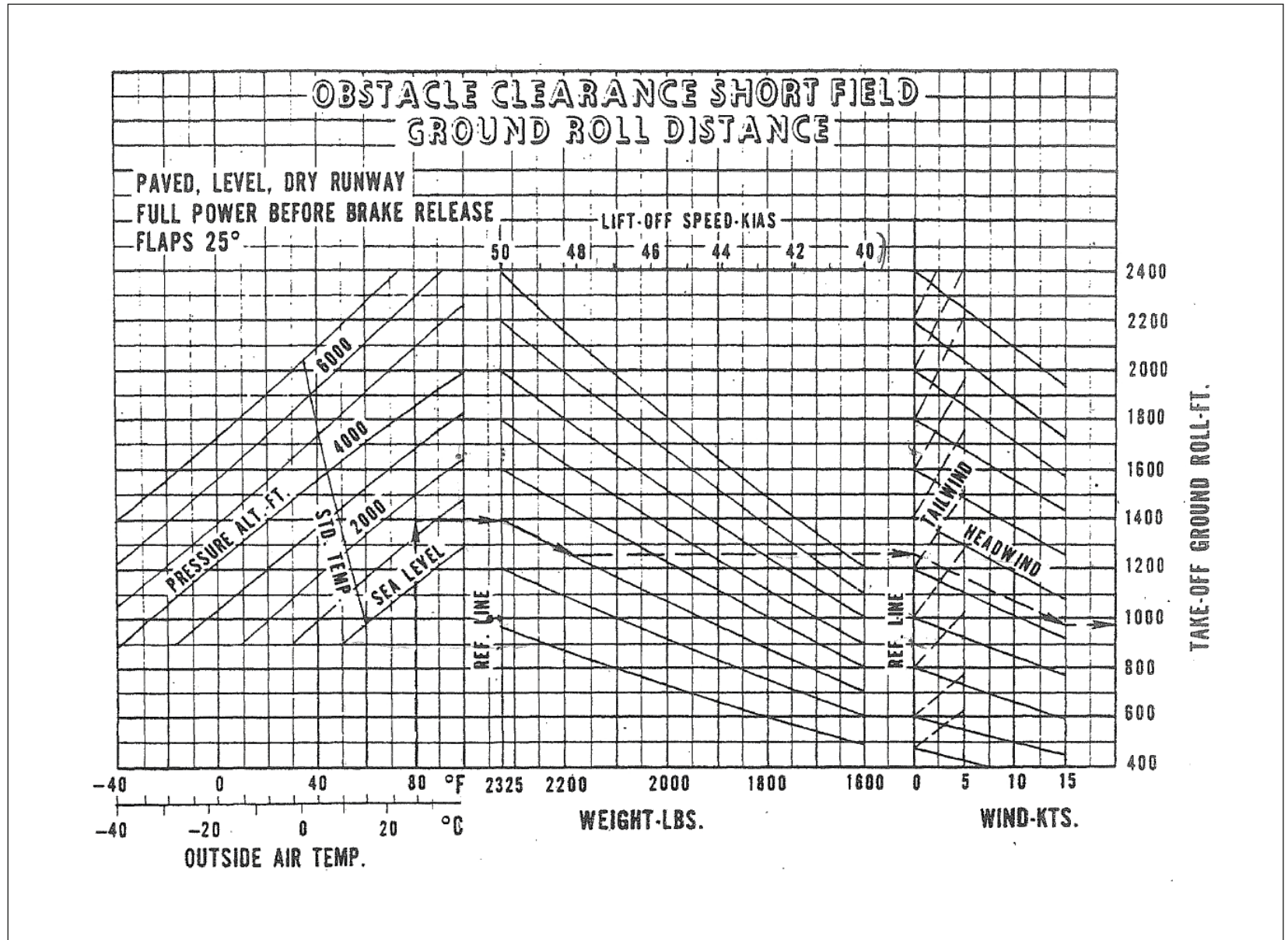

Obstacle clearance short field take-off distance

Example

Departure airport pressure altitude: 1,500ft

Departure airport temperature: 80°F (27°C)

Weight: 2,175 lb

Wind: 15 knots headwind

Distance over 50ft barrier: 1,600ft

Lift-off speed: 48 KIAS

Barrier speed: 53 KIAS

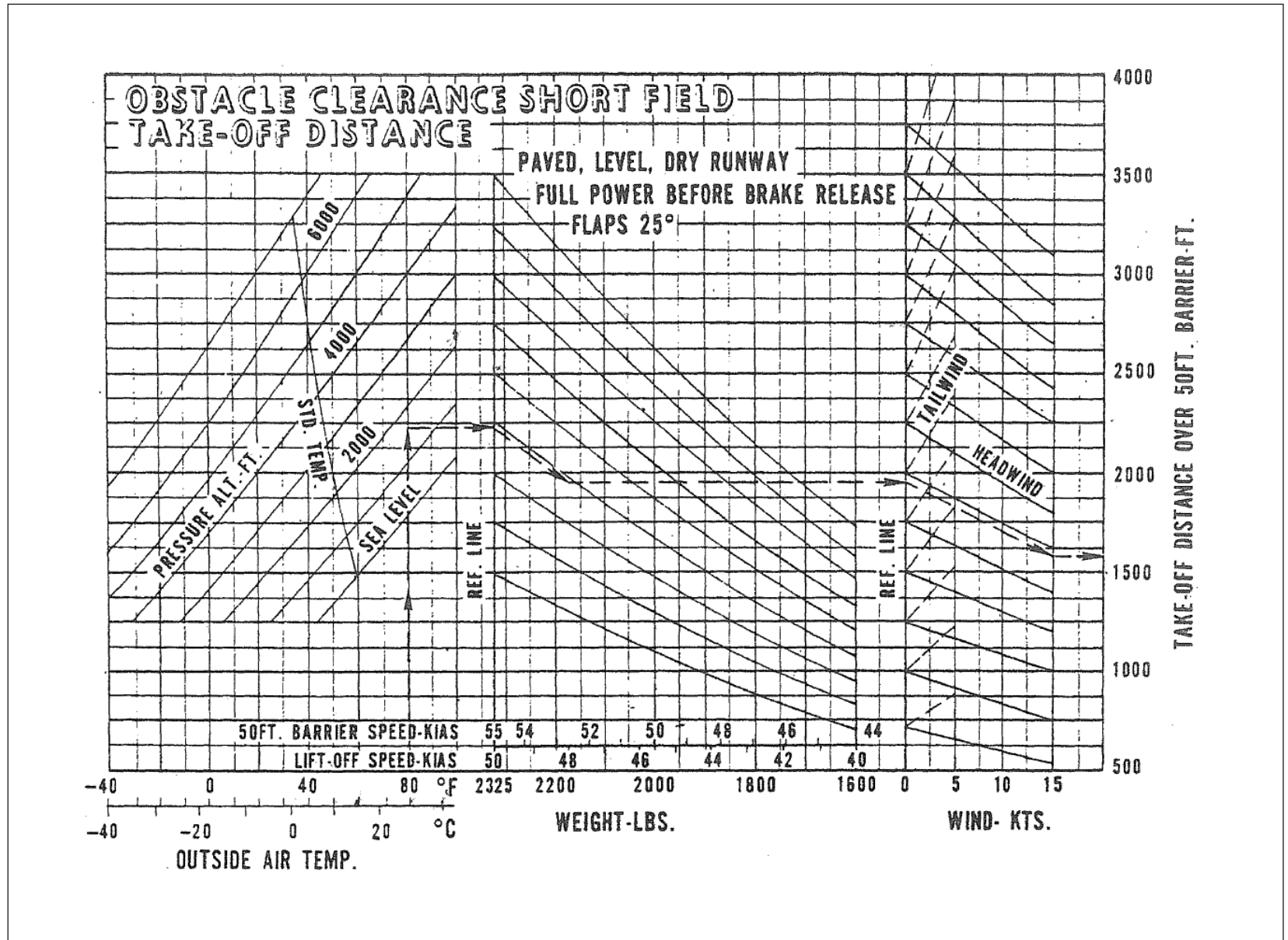

CLIMB PERFORMANCE

Climb performance

Example

Climb pressure altitude:
5,000ft

Climb OAT: 60°F

Rate of climb: 420 ft/min

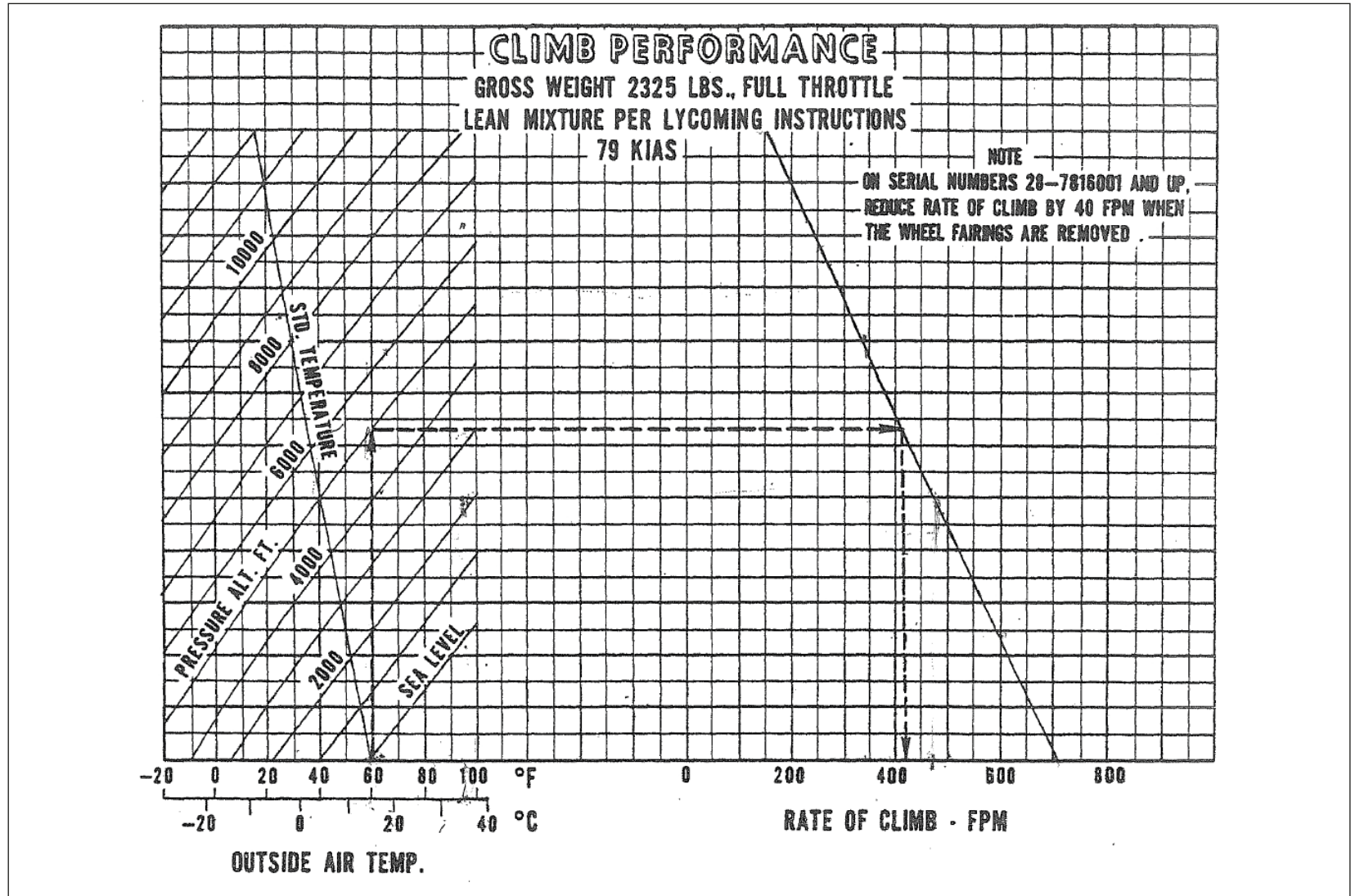

Fuel, time and distance to climb

Example

Departure airport pressure altitude: 1,500ft

Departure airport temperature: 80°F (27°C)

Climb pressure altitude: 5,000ft

Cruise OAT: 60°F (16°C)

Time to climb: 10 mins
minus 2.5 mins – 7.5 mins

Distance to climb: 13.5
miles minus 3.5 miles – 10
nautical miles

Fuel to climb: 2 gallons
minus 0.5 gallons – 1.5
gallons

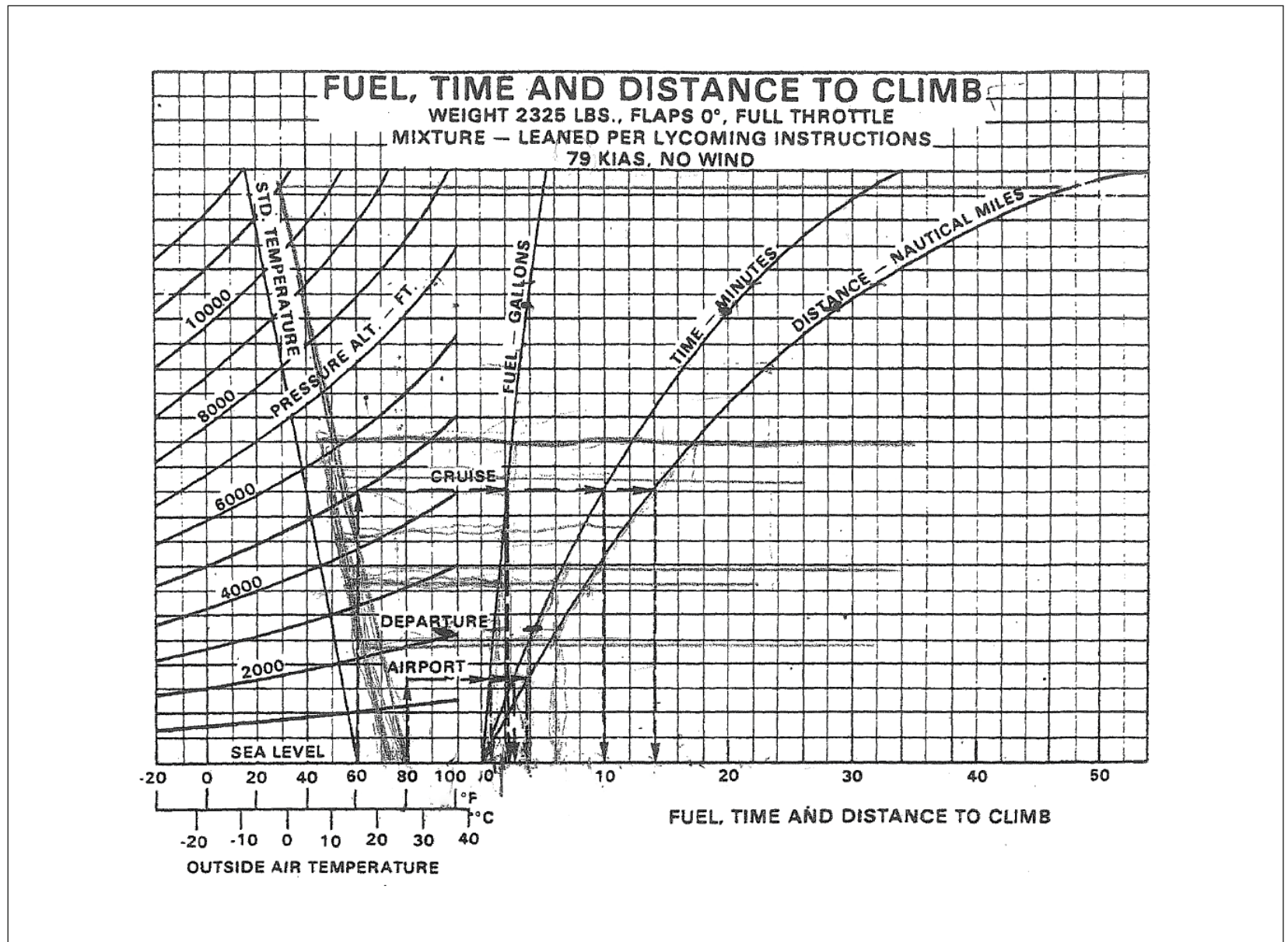

LEVEL FLIGHT PERFORMANCE

Best power cruise performance

Example

Cruise pressure altitude:
5,000ft

Cruise OAT: 60°F (16°C)

Cruise power: 75% best
power mixture

Cruise speed: 122.5 knots
TAS

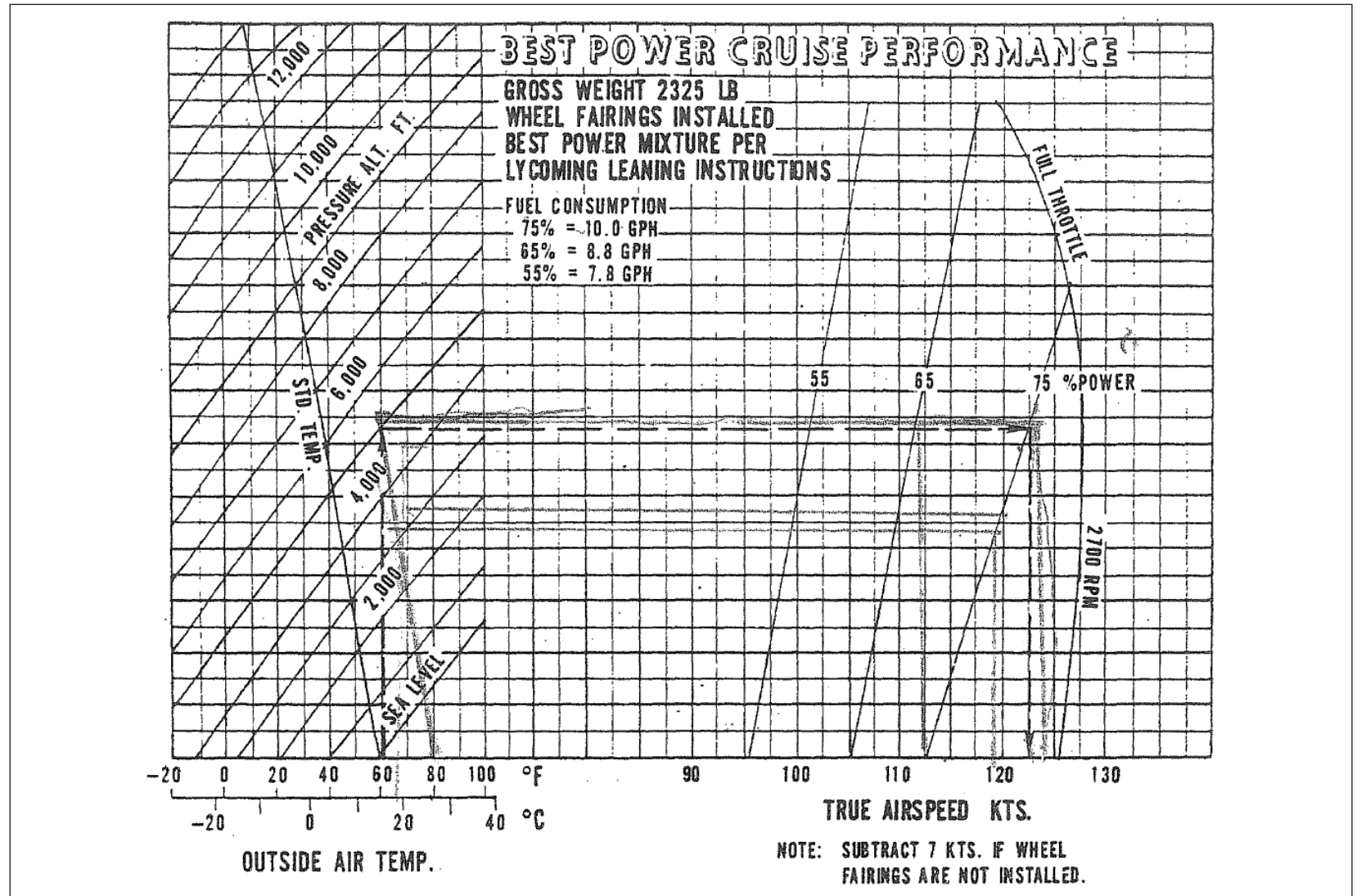

Best economy cruise performance

Example

Cruise pressure altitude:
5,000ft

Cruise OAT: 60°F (16°C)

Cruise power: 75% best
economy mixture

Cruise speed: 112.5 knots
TAS

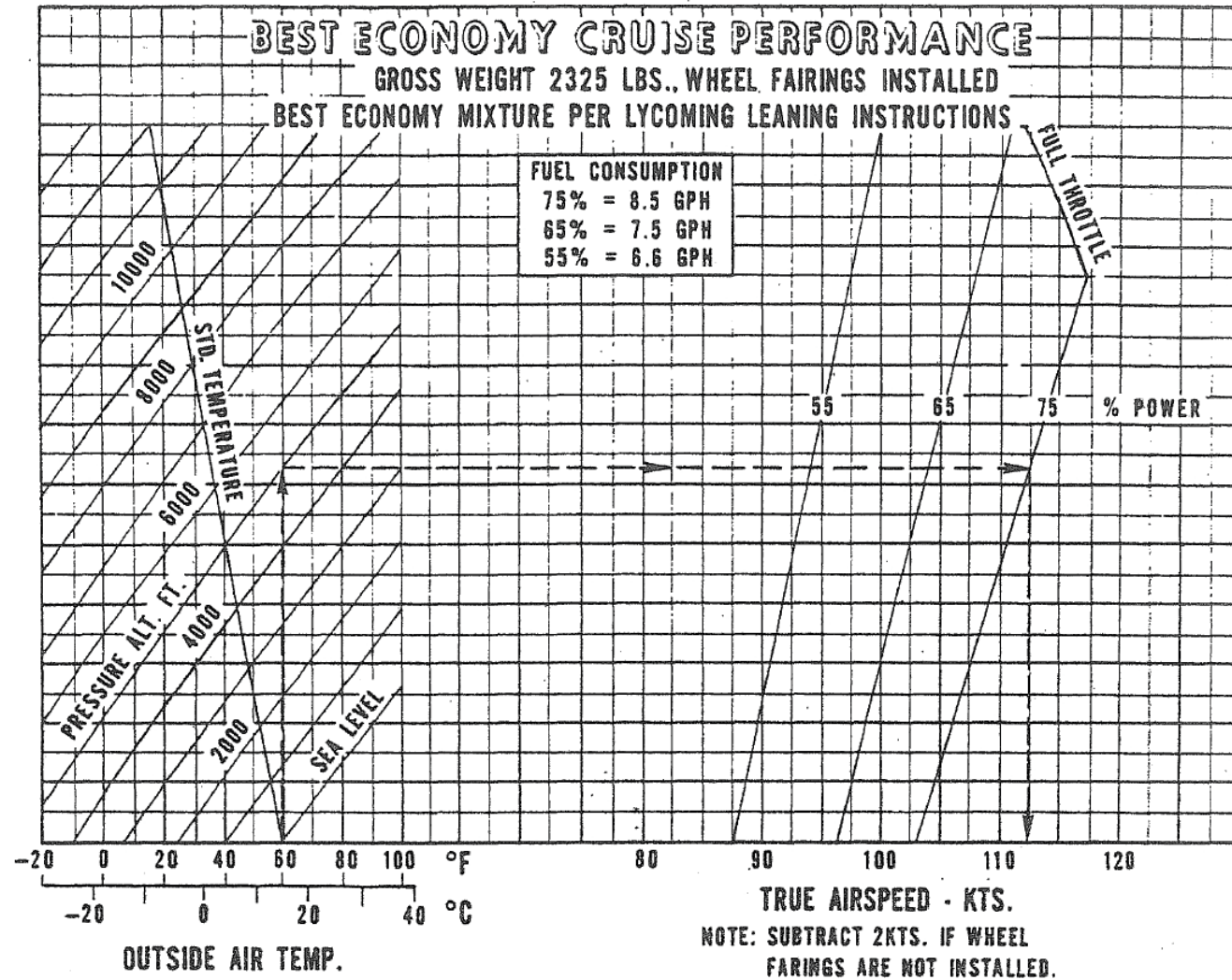

Best power mixture range

Example

Cruise pressure altitude:
5,000ft

Cruise OAT: 60°F (16°C)

Cruise power: 75% best
power mixture

Range with 45 mins reserve
@ 55% power: $501 + (0.6 \times 11) = 507.6$ nautical miles

Range with no reserve: $561 + (0.6 \times 11) = 567.6$ nautical miles

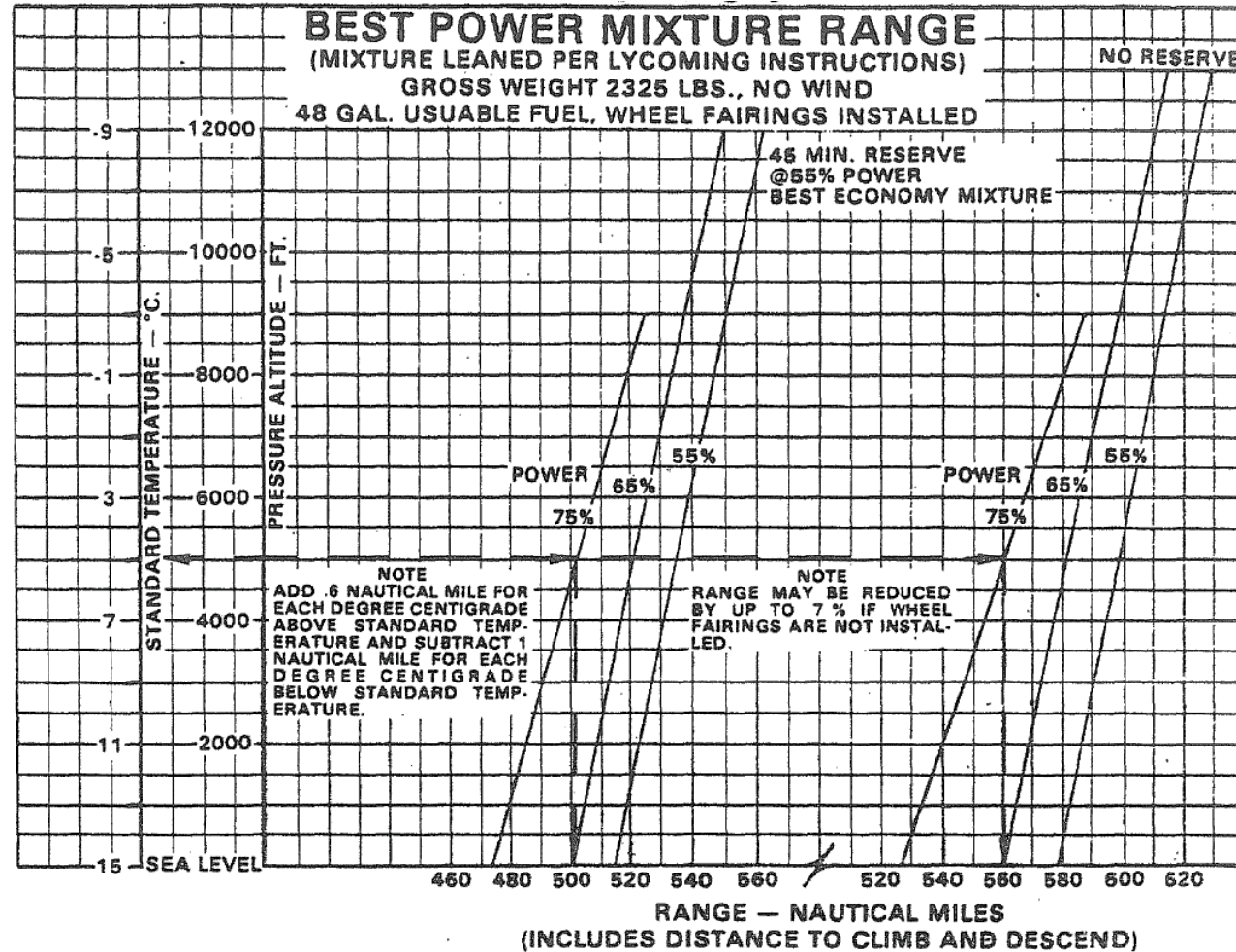

Best economy mixture range

Example

Cruise pressure altitude:
5,000ft

Cruise OAT: 60°F (16°C)

Cruise power: 75% best
economy mixture

Range with 45 mins reserve
@ 55% power: $567 + (0.7 \times 11) = 574.7$ nautical miles

Range with no reserve: $635 + (0.7 \times 11) = 642.7$ nautical miles

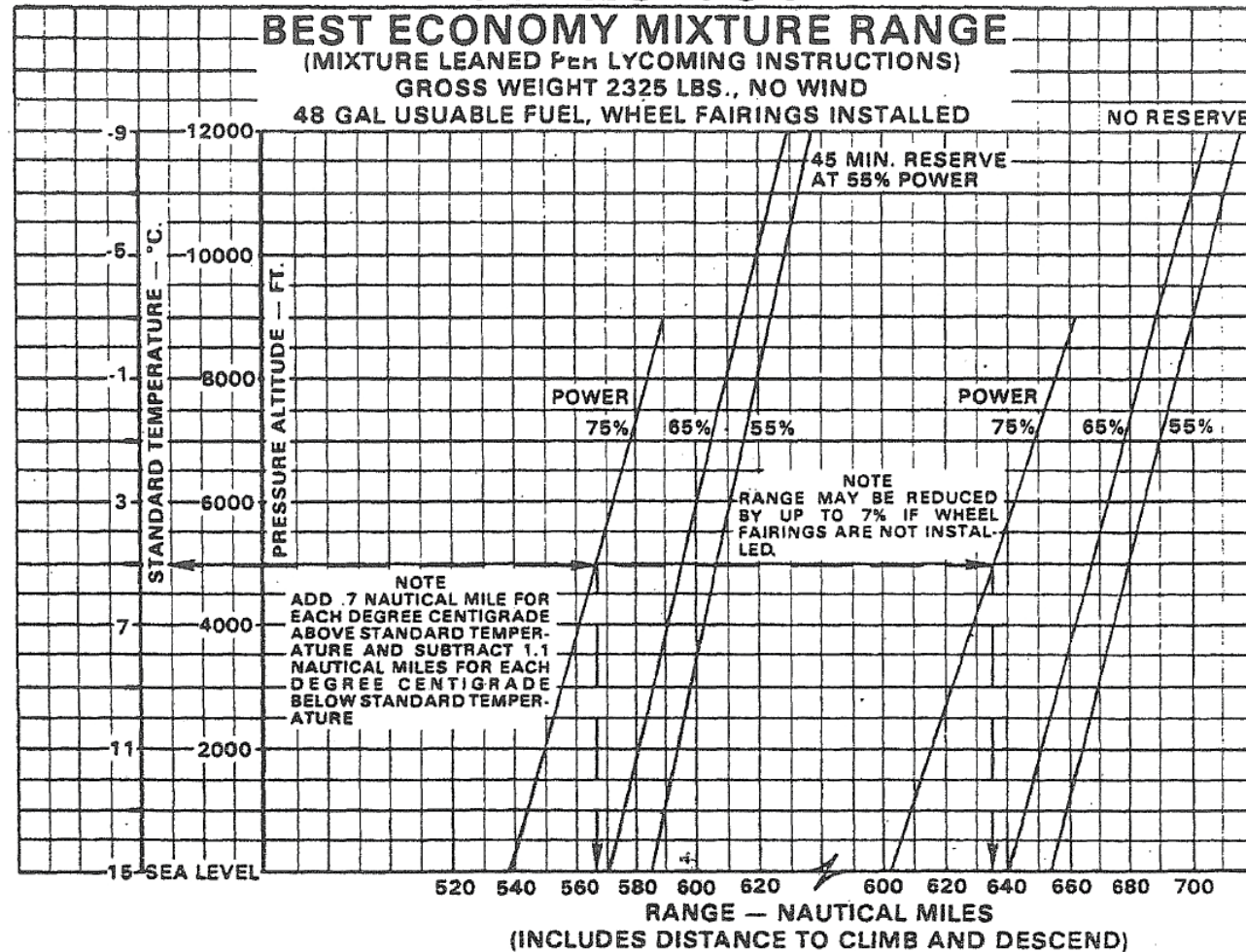

Endurance

Example

Cruise pressure altitude:
5,000ft

Cruise power: 75% best
economy mixture

Range with 45 mins reserve
@ 55% power: 4.85 hrs

Range with no reserve: 5.45
hrs

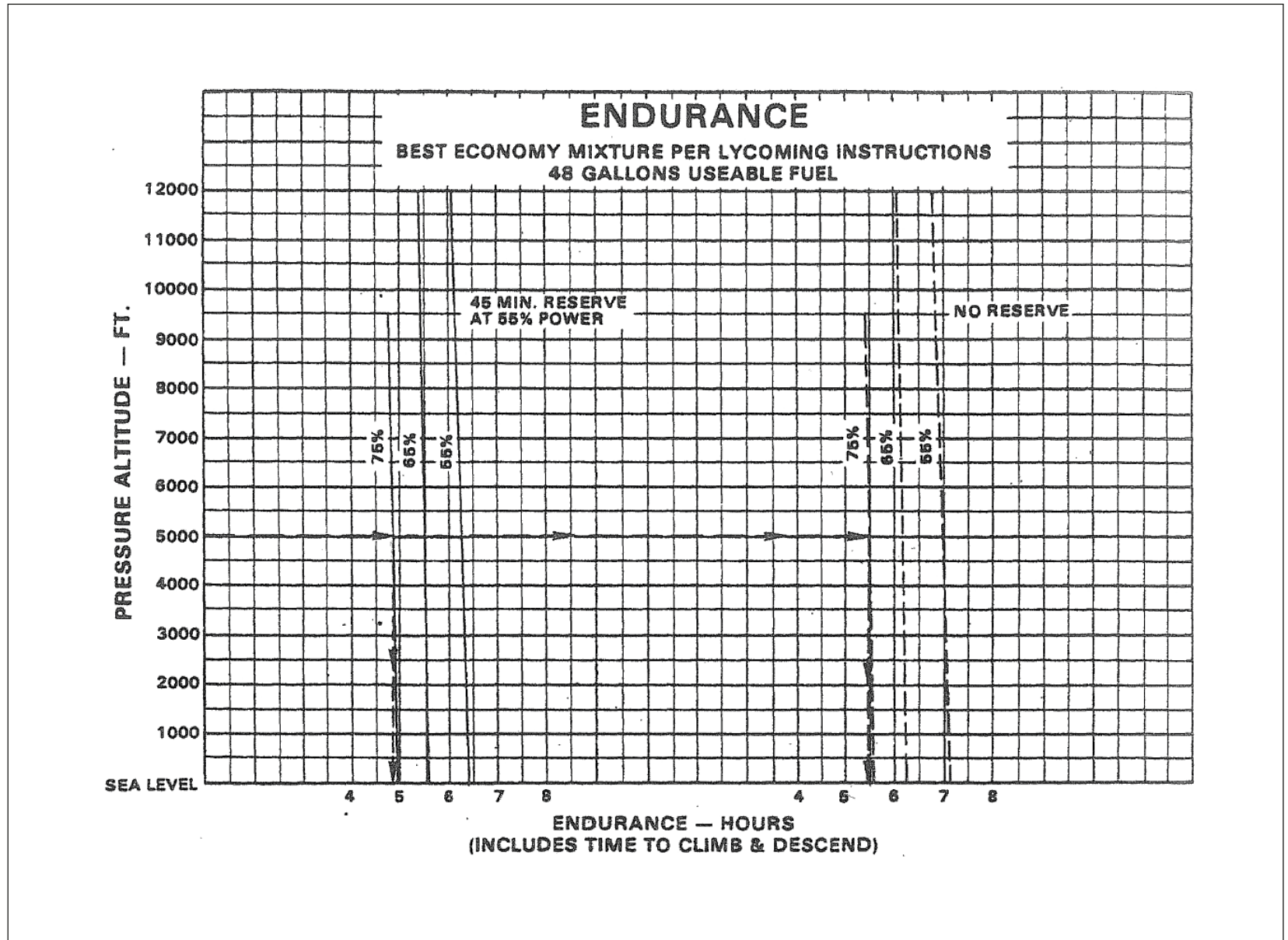

DESCENT PERFORMANCE

Fuel, time and distance to descend

Example

Departure airport pressure altitude: 2,500ft

Departure airport temperature: 75°F (24°C)

Climb pressure altitude: 5,000ft

Cruise OAT: 60°F (16°C)

Time to descend: 6.5 mins
minus 3.5 mins – 3 mins

Distance to descend: 14
miles minus 7.5 miles – 6.5
nautical miles

Fuel to descend: 1 gallon
minus 0.5 gallons – 0.5
gallons

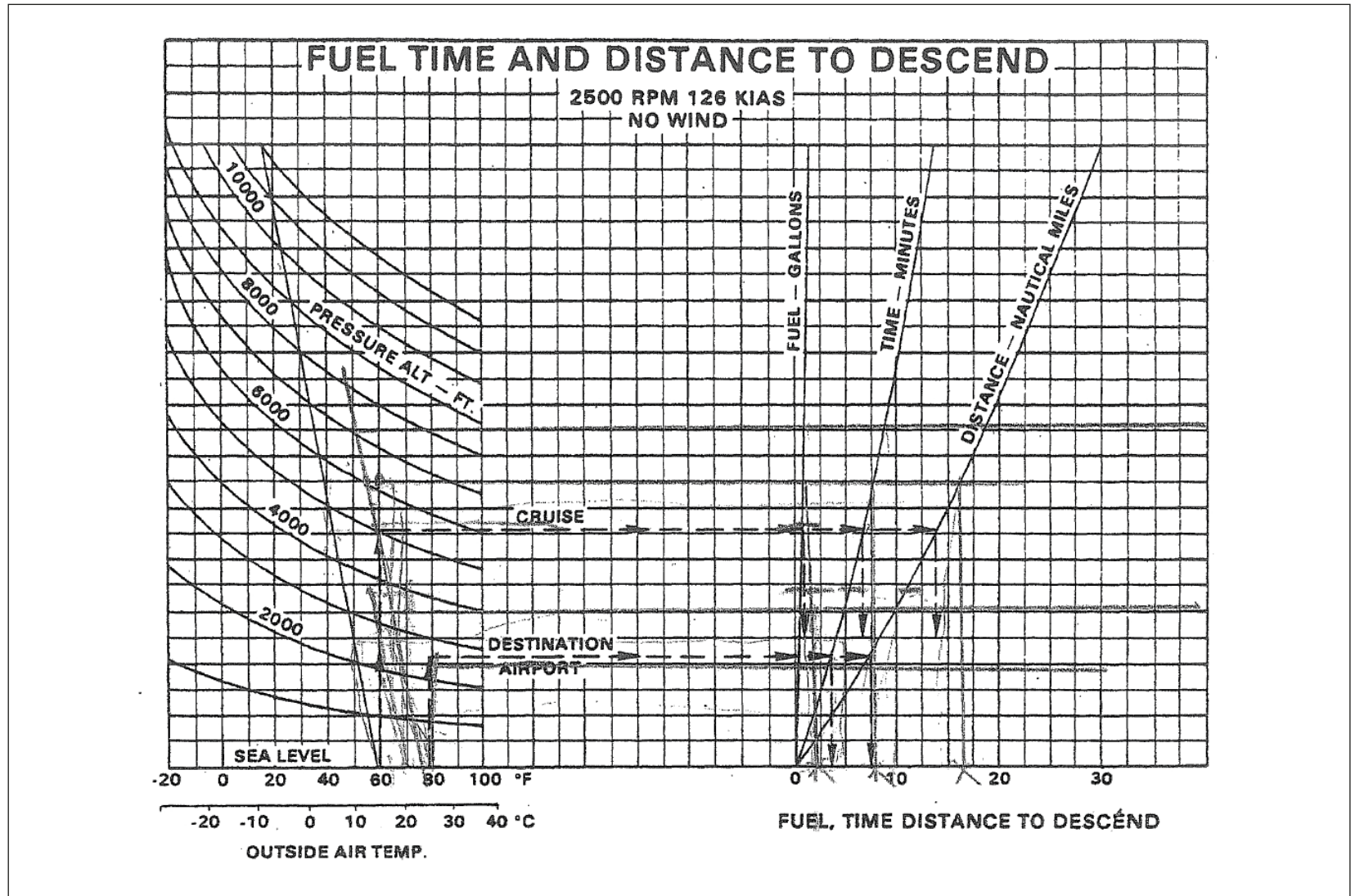

Glide performance

Example

Cruise pressure altitude:
5,000ft

Terrain pressure altitude:
2,000ft

Glide distance (9.5 miles
minus 3.8 miles): 5.7 miles

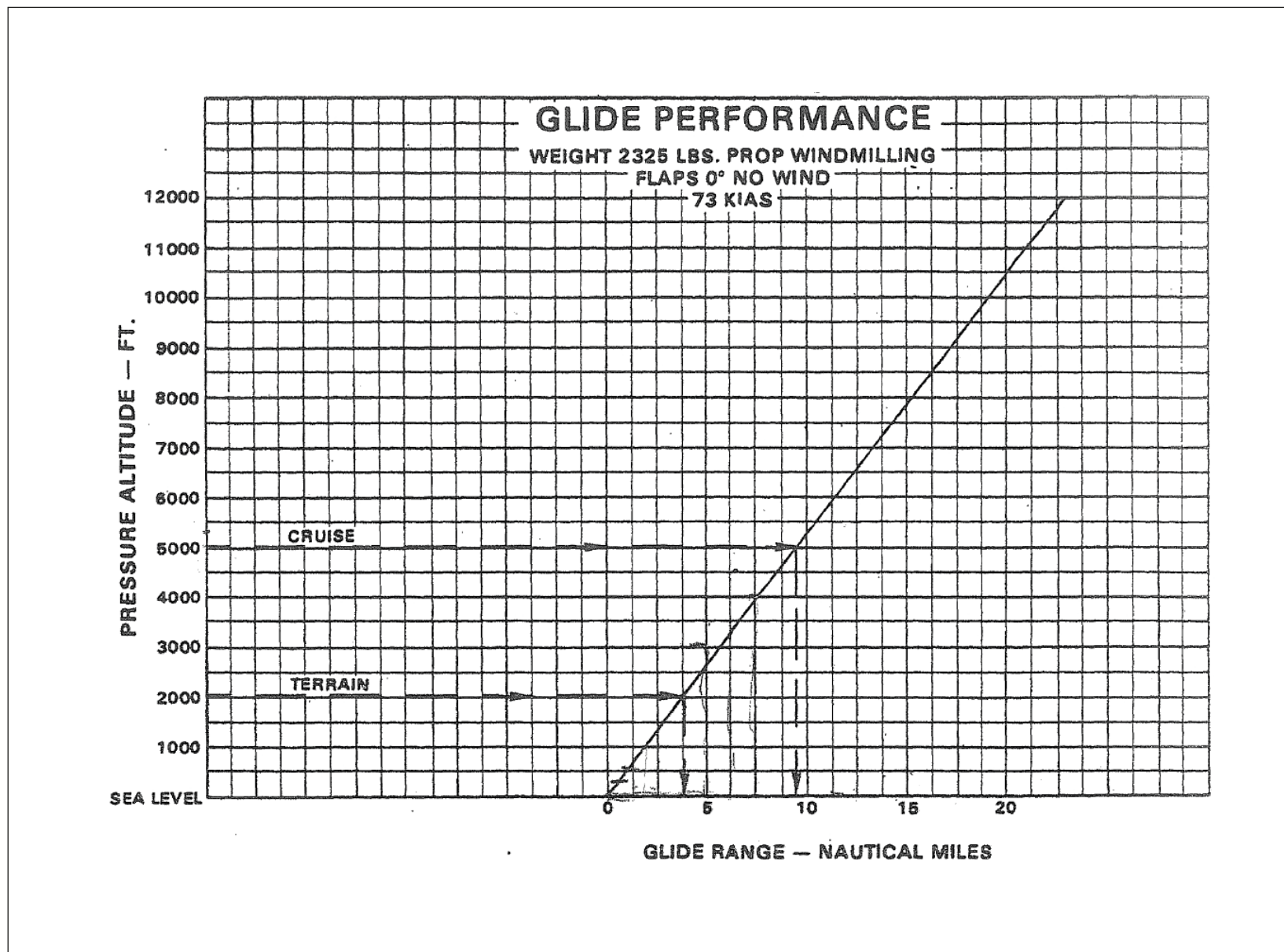

LANDING PERFORMANCE

Landing performance

Example

Destination airport pressure altitude: 2,500ft

Destination airport temperature: 75°F (24°C)

Destination airport wind: 0 knots

Ground roll: 660ft

Distance over 50ft barrier: 1,190ft

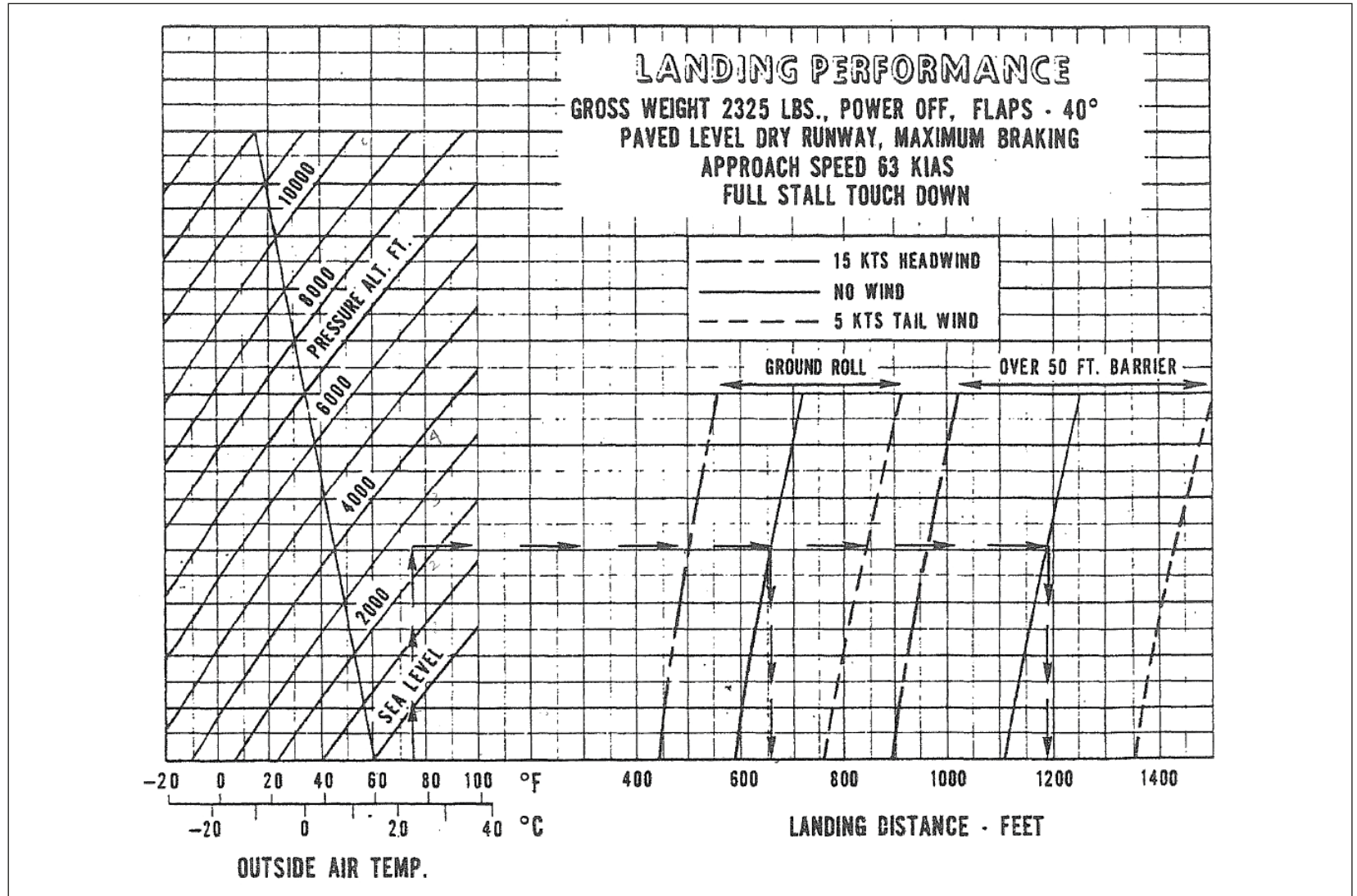

Just Flight[™]
www.justflight.com